

SIS

A SPECIALIST IN BRAZING ALLOYS

**SAITAMA INDUSTRIES PTE . LTD.
SAITAMA INDUSTRIES SDN. BHD.**

SIS COMPANY PROFILE

SAITAMA INDUSTRIES SDN. BHD. was established on January 1993.

Our head office is located in Singapore & our factory in Johor, Malaysia. We are ISO9001 & ISO14001 certified, and fully RoHS free compliance. We also have several overseas locations : Tokyo (Japan), Shanghai (China), Taipei (Taiwan), India, etc to serve our existing customers and take care of worldwide market. Customer confidence and trust is of the highest priority to us.

Our Product Range:

- (1) **Copper Phosphorous Brazing Alloys (BCuP-series)**
- (2) **Silver Brazing Alloys (BAg-series) – include high silver**
- (3) **Aluminum Brazing Alloys (4047-series)**

Every manufacturing process (from melting to finishing alloy) is performed internally in our factory to produce all kinds of brazing alloys: **ROD, WIRE, RING, SPOOL**. We are capable of providing **STANDARD spec & ANY CUSTOMIZED** spec for our customers due to our 1-stop manufacturing services, which is unique in the brazing alloy market.

Major industries served : Air-Conditioner, Heat exchanger, Refrigeration fittings, Freezer, Motors, Compressors, Automotive, Ship building areas, Medical, Retail, and many more applications.

Our Major Customers: TAPS, Daikin, Panasonic, Toshiba, Mitsubishi, Hitachi, and many others.....





Silver Brazing Alloys

Copper-Phosphorous Brazing Alloys

Aluminum Brazing Alloys



Brazing Wire



Brazing Wire in Plastic Spool



Brazing Rod



Brazing Ring



Brazing Ring



Aluminum wire/ring

SIS RING SPECIFICATION CONTROL

Dimension : mm

S/N	Size	Inner Diameter			Outer Diameter	d	t	h2	Material Type	
		ID	ID Min	ID Max	OD Max					
1.	1.3 x 4.9	4.90	+0.05 -0.05	4.85	4.95	≤7.50	∅ 1.30 ±0.10	≤0.10	≤1.45	BCuP-2
2.	1.4 x 6.25	6.25	+0.00 -0.15	6.10	6.25	≤9.15	∅ 1.40 ±0.10	≤0.10	≤1.50	BCuP-6
3.	1.4 x 6.9	6.90	+0.00 -0.15	6.75	6.90	≤9.80	∅ 1.40 ±0.10	≤0.10	≤1.50	BCuP-2
4.	1.5 x 6.25	6.25	+0.05 -0.05	6.20	6.30	≤9.30	∅ 1.50 +0.10 -0.00	≤0.10	≤1.60	BCuP-2
5.	1.5 x 16.0	16.00	+0.10 -0.10	15.90	16.10	≤19.20	∅ 1.50 ±0.05	≤0.10	≤1.60	SB 382
6.	1.5 x 17.5	17.50	+0.00 -0.20	17.30	17.50	≤20.60	∅ 1.50 ±0.05	≤0.10	≤1.60	SB 382
7.	1.6 x 6.9	6.90	+0.00 -0.15	6.75	6.90	≤10.15	∅ 1.60 ±0.05	≤0.10	≤1.65	BCuP-2 / BCuP-6
8.	1.6 x 7.9	7.90	+0.00 -0.15	7.75	7.90	≤11.12	∅ 1.60 ±0.05	≤0.10	≤1.65	BCuP-2 / BCuP-6 / BCuP-3
9.	1.6 x 9.4	9.40	+0.00 -0.15	9.25	9.40	≤12.65	∅ 1.60 ±0.05	≤0.10	≤1.65	BCuP-2 / BCuP-6
10.	1.6 x 10.0	10.00	+0.00 -0.20	9.80	10.00	≤13.30	∅ 1.60 ±0.05	≤0.10	≤1.70	SB 451
11.	1.8 x 6.9	6.90	+0.00 -0.15	6.75	6.90	≤10.60	∅ 1.80 ±0.05	≤0.10	≤1.85	BCuP-2
12.	1.8 x 7.9	7.90	+0.00 -0.15	7.75	7.90	≤11.55	∅ 1.80 ±0.05	≤0.10	≤1.85	BCuP-2 / BCuP-3
13.	1.8 x 9.4	9.40	+0.00 -0.15	9.25	9.40	≤13.05	∅ 1.80 ±0.05	≤0.10	≤1.85	BCuP-2
14.	2.4 x 12.7	12.70	+0.10 -0.10	12.60	12.80	≤17.60	∅ 2.40 ±0.05	≤0.10	≤2.60	BCuP-6
15.	0.8 x 3.95 (double ring)	3.95	+0.00 -0.15	3.80	3.95	≤5.60	∅ 0.80 ±0.10	NA	≤1.70	BCuP-2
16.	1.1 x 4.95 (double ring)	4.95	+0.00 -0.15	4.80	4.95	≤7.20	∅ 1.10 ±0.10	NA	≤2.30	BCuP-2
17.	1.3 x 5.05 (double ring)	5.05	+0.00 -0.10	4.95	5.05	≤7.75	∅ 1.30 ±0.10	NA	NA	BCuP-2

ANY CUSTOMISED SPECIFICATION IS WELCOMED

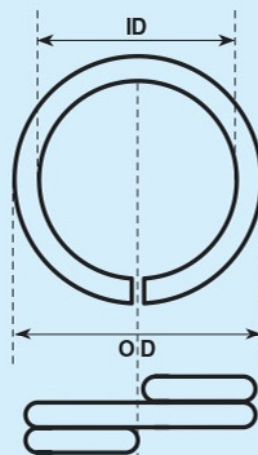
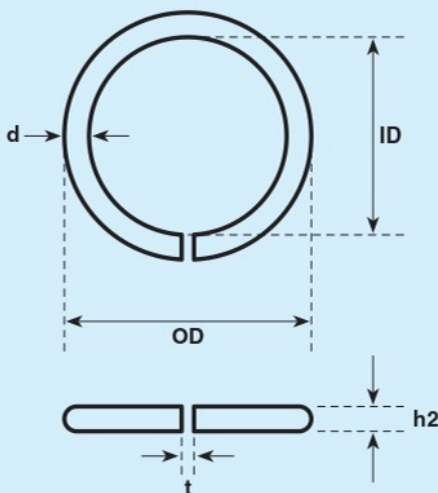

ID : Inner Diameter
OD : Outer Diameter
d : Wire Diameter
h2 : Flatness Height
t : Gap

APPEARANCE OF RING

All ring shall be free from any defects apparent scratch, die mark, inside burr and sharp burr.

SIS PRODUCTS SPECIFICATION

SILVER BRAZING ALLOYS

Alloy Name	JIS / AWS Spec. No.	Nominal Composition %				Melting Point °C	Flow Point °C	Working Range °C	Conductivity (I.A.C.S. %)	Density
		Ag	Cu	Zn	Others					
SIL-BRA 450	BAG-5	45	30	25		665	745	745 - 845	19.0	9.11
SIL-BRA 403	BAG-4	40	30	28	(Ni) ₂	660	780	780 - 900	16.8	9.06
SIL-BRA 451		45	25	29	(Sn) ₁	664	700	700 - 800	18.5	9.1
SIL-BRA 452		45	25	29	(Sn) ₁	664	700	700 - 800	18.0	9.1
SIL-BRA 402	BAG-28	40	30	28	(Sn) ₂	649	710	710 - 810	18.0	9.0
SIL-BRA 4021	BAG-28	40	30	28	(Sn) ₂	649	710	710 - 843		9.6
SIL-BRA 400		40	30	30		675	725	730 - 830	20.8	8.9
SIL-BRA 382	BAG-34	38	32	28	(Sn) ₂	649	721	721 - 830	18.0	9.1
SIL-BRA 352		35	33	30	(Sn) ₂	655	740	740 - 840	19.6	9.0
SIL-BRA 3521		35	33	30	(Sn) ₂	660	740	740 - 840	19.6	8.9
SIL-BRA 384		38	30	30	(In) ₂	680	730	730 - 830	18.5	9.1

COPPER-PHOSPHOROUS BRAZING ALLOYS

Alloy Name	JIS / AWS Spec. No.	Nominal Composition %			Melting Point °C	Flow Point °C	Working Range °C	Conductivity (I.A.C.S. %)	Density
		Ag	Cu	P					
FOS-BRA 2060		20	74	6	645	710	690 - 720	9.6	8.6
FOS-BRA 1550	BCuP - 5	15	80	5	645	815	690 - 820	9.9	8.5
FOS-BRA 670	BCuP - 4	6	87	7	645	720	690 - 730	9.5	8.4
FOS-BRA 560	BCuP - 3	5	89	6	645	805	690 - 820	9.5	8.4
FOS-BRA 270	BCuP - 6	2	91	7	645	780	690 - 800	8.5	8.1
FOS-BRA 170		1	92	7	645	820	690 - 830	7.2	8.1
FOS-BRA 70	BCuP - 2		93	7	714	805	750 - 820	7.0	8.0
FOS-BRA 65			93.5	6.5	714	830	750 - 850	7.1	8.2
FOS-BRA 50	BCuP - 1		95	5	714	920	780 - 850	9.2	8.4

BRONZE BRAZING ALLOYS

Alloy Name	JIS / AWS Spec. No.	Nominal Composition %				Melting Point °C	Flow Point °C	Working Range °C	Conductivity (I.A.C.S. %)	Density g/cm3
		Ag	Cu	Zn	Others					
B-BRA 602	BCu-6B/ RBCuZn-A		60	39	(Sn) ₁	885	900	910 - 960	N/A	8.4
B-BRA 555		5	55	40		848	874	880 - 910	19	8.5

BASE METAL	Typical Uses & Brazing Characteristics
BRASS	General purpose filler metal for steel alloys and copper alloys. For ships' piping, band instruments, aircraft engine oil coolers, brass lamps, compressors.
SUS	Nickel content improves wetlability on tungsten carbide tool tips and also works on corrosion resistance of stainless steel joint.
BRASS	For Brass-made parts or small-sized steel parts utilizing its lower F.P.
SS41	Free-flowing intermediate temperature filler metal and is used in cadmium-free brazing applications such as air-conditionings and refrigerations which involve the joining of steels, coppers and copper alloys. Higher Ag content one is preferably used for brass-made components on small parts assemblies.
SS41	
SS41	
SS41	
SS41	
SS41	
SS41	In content works to lower F.P. maintaining the tenacity of the brazing metal.

BASE METAL	Typical Uses & Brazing Characteristics
BRASS	Free flowing and self-fluxing on copper by virtue of phosphor content.
BRASS	These were developed primarily for use on copper, but their use has extended to other nonferrous copper base alloys.
BRASS	
BRASS	They are used extensively on refrigeration units, air conditioning apparatus, electrical conductors, copper and brass pipe fittings and other copper and brass equipments.
BRASS	Higher silver content alloys are recommended to use where critical impact or vibrational stress will be encountered in services.
BRASS	
COPPER	Low cost brazing filler metal suitable for joining copper to copper where critical impact or vibration stresses are not encountered in service. This should only be used on assemblies where good fit up can be maintained.
COPPER	Similarly used as FOS-BRA 70 but FOS-BRA 65 flows more sluggishly and works on rougher fit joints.
COPPER	Cu-Cu joint successively followed by brazing at lower temperature.

BASE METAL	Typical Uses & Brazing Characteristics
Low Carbon Steel, Brass, Bronze, Copper	For plumbing and for small parts assemblies.



SINGAPORE HEAD OFFICE:

SAITAMA INDUSTRIES PTE. LTD.

8 BOON LAY WAY #06-08, TRADEHUB 21, SINGAPORE 609964

TEL: (65) 6861 9119 / 6861 9368 FAX: (65) 6861 4605

E-MAIL: saitama@singnet.com.sg

MALAYSIA FACTORY:

SAITAMA INDUSTRIES SDN. BHD.

LOT 39747, JALAN TEMBAGA 1, DESA PERINDUSTRIAN KULAI,
81000 KULAI, JOHOR, MALAYSIA.

TEL: +607-652 2130 / 607-652 3162 FAX: +607-652 1149

E-MAIL: info@saitama.com.my

WEBSITE: <http://www.saitama.com.my>

┌ Partners:

┐

└

┘